

DATASHEET

Toss Self Adhesive PTFE Tape



Operating Instructions

PTFE cover strip is used to create a non-stick surface that prevents melted material from sticking to the sealing components during the sealing process. Using a PTFE cover strip overtop of the heat seal band ensures smooth and consistent sealing without any risk of material buildup or contamination. PTFE tape is highly heat-resistant and can withstand the intense temperatures generated during impulse heat sealing, maintaining its integrity and effectiveness over numerous sealing cycles. Standard sizes range from 20mm wide with an effective zone of 8mm up to 44mm wide with an effective zone of 20mm. Custom sizes can be ordered.

PTFE Tape in Jaw Bar Build Up

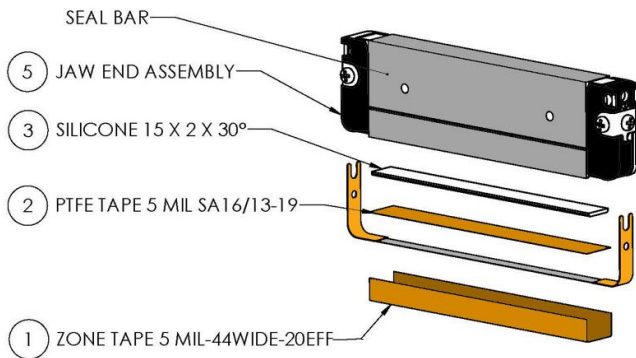

Specifications

	SA16/15 (6mil)	SA16/13 (5mil)	SA08/8 (3 mil)
Substrate Type	PTFE Coated, Woven Fiberglass ("E" type)	PTFE Coated, Woven Fiberglass ("E" type)	PTFE Coated, Woven Fiberglass ("E" type)
Adhesive Type	High Temperature Silicone		
Overall Thickness (nominal)	.008 in. .2032 mm	.007 in. .1778 mm	.0052 in. .1321 mm
Substrate Thickness (nominal)	.0058 in. .1473 mm	.0048 in. .1219 mm	.0030 in. .0762 mm
Adhesive Thickness (nominal)	.0022 in. .05588 mm		
Operating Temperature	-100°F to 500°F -73° C to 260°C		
Dielectric Strength (nominal)	8,500 volts	7,500 volts	5,000 volts
Peel Strength (nominal)	50 ounces/ inch of width 27.47 Newtons/ 5cm	50 ounces/ inch of width 27.47 Newtons/ 5cm	40 ounces/ inch of width 21.98 Newtons/ 5cm
Adhesive Shelf Life	6-12 months		

Our Experience and Technology Today Your Progress and Profit Tomorrow